

CIRCUIT-BREAKER SZ S00, FOR MOTOR PROTECTION, CLASS 10, A-RELEASE 10...16A, N-RELEASE 208A, SCREW CONNECTION, STANDARD SW. CAPACITY W. TRANSVERSE AUX. SWITCH 1NO+1NC



product brand name	SIRIUS
Product designation	3RV2 circuit breaker
<b>General technical data:</b>	
Size of the circuit-breaker	S00
Size of contactor can be combined company-specific	S00, S0
Product extension	
• Auxiliary switch	Yes
Power loss [W] total typical	7 W
Insulation voltage with degree of pollution 3 rated value	690 V
Surge voltage resistance rated value	6 kV
maximum permissible voltage for safe isolation	
• in networks with grounded star point between main and auxiliary circuit	400 V
• in networks with grounded star point between main and auxiliary circuit	400 V
Protection class IP	
• on the front	IP20
• of the terminal	IP20

<b>Shock resistance</b>	
• acc. to IEC 60068-2-27	25g / 11 ms
<b>Mechanical service life (switching cycles)</b>	
• of the main contacts typical	100 000
• of auxiliary contacts typical	100 000
<b>Electrical endurance (switching cycles)</b>	
• typical	100 000
<b>Type of protection</b>	Increased safety
<b>Certificate of suitability relating to ATEX</b>	on request
<b>Protection against electrical shock</b>	finger-safe
Equipment marking acc. to DIN EN 81346-2	Q

#### Ambient conditions:

<b>Installation altitude at height above sea level maximum</b>	2 000 m
<b>Ambient temperature</b>	
• during operation	-20 ... +60 °C
• during storage	-50 ... +80 °C
• during transport	-50 ... +80 °C
<b>Temperature compensation</b>	-20 ... +60 °C
<b>Relative humidity during operation</b>	10 ... 95 %

#### Main circuit:

<b>Number of poles for main current circuit</b>	3
<b>Adjustable pick-up value current of the current-dependent overload release</b>	10 ... 16 A
<b>Operating voltage</b>	
• rated value	690 V
• at AC-3 rated value maximum	690 V
<b>Operating frequency rated value</b>	50 ... 60 Hz
<b>Operating current rated value</b>	16 A
<b>Operating current</b>	
• at AC-3	
— at 400 V rated value	16 A
<b>Operating power</b>	
• at AC-3	
— at 230 V rated value	4 000 W
— at 400 V rated value	7 500 W
— at 500 V rated value	7 500 W
— at 690 V rated value	11 000 W
<b>Operating frequency</b>	
• at AC-3 maximum	15 1/h

#### Auxiliary circuit:

<b>Design of the auxiliary switch</b>	transverse
<b>Number of NC contacts</b> • for auxiliary contacts	1
<b>Number of NO contacts</b> • for auxiliary contacts	1
<b>Number of CO contacts</b> • for auxiliary contacts	0
<b>Operating current of auxiliary contacts at AC-15</b> • at 24 V • at 120 V • at 125 V • at 230 V	2 A 0.5 A 0.5 A 0.5 A
<b>Operating current of auxiliary contacts at DC-13</b> • at 24 V • at 60 V	1 A 0.15 A

Protective and monitoring functions:	
<b>Trip class</b>	Class 10
<b>Design of the overload release</b>	thermal
<b>Operational short-circuit current breaking capacity (Ics) at AC</b> • at 240 V rated value • at 400 V rated value • at 500 V rated value • at 690 V rated value	100 kA 30 kA 5 kA 2 kA
<b>Maximum short-circuit current breaking capacity (Icu)</b> • at AC at 240 V rated value • at AC at 400 V rated value • at AC at 500 V rated value • at AC at 690 V rated value	100 kA 55 kA 10 kA 4 kA
<b>Breaking capacity short-circuit current (Icn)</b> • at 1 current path at DC at 150 V rated value • with 2 current paths in series at DC at 300 V rated value • with 3 current paths in series at DC at 450 V rated value	10 kA 10 kA 10 kA

UL/CSA ratings:	
<b>Full-load current (FLA) for three-phase AC motor</b> • at 480 V rated value • at 600 V rated value	16 A 16 A
<b>Yielded mechanical performance [hp]</b> • for single-phase AC motor — at 110/120 V rated value	1 hp

<ul style="list-style-type: none"> <li>— at 230 V rated value</li> <li>• for three-phase AC motor <ul style="list-style-type: none"> <li>— at 200/208 V rated value</li> <li>— at 220/230 V rated value</li> <li>— at 460/480 V rated value</li> </ul> </li> </ul>	2 hp  3 hp  5 hp  10 hp
<b>Contact rating of auxiliary contacts according to UL</b>	C300 / R300

### Short-circuit protection

<b>Design of the short-circuit trip</b>	magnetic
<b>Design of the fuse link</b> <ul style="list-style-type: none"> <li>• for short-circuit protection of the auxiliary switch required</li> </ul>	Fuse gL/gG: 10 A, miniature circuit breaker C 6 A (short-circuit current $I_k < 400$ A)
<b>Design of the fuse link for IT network for short-circuit protection of the main circuit</b> <ul style="list-style-type: none"> <li>• at 240 V</li> <li>• at 400 V</li> <li>• at 500 V</li> <li>• at 690 V</li> </ul>	gL/gG 80 A gL/gG 63 A gL/gG 50 A gL/gG 40 A

### Installation/ mounting/ dimensions:

<b>Mounting position</b>	any
<b>Mounting type</b>	screw and snap-on mounting onto 35 mm standard mounting rail according to DIN EN 60715
<b>Height</b>	97 mm
<b>Width</b>	45 mm
<b>Depth</b>	96 mm
<b>Required spacing</b> <ul style="list-style-type: none"> <li>• with side-by-side mounting <ul style="list-style-type: none"> <li>— forwards</li> <li>— Backwards</li> <li>— upwards</li> <li>— downwards</li> <li>— at the side</li> </ul> </li> <li>• for grounded parts <ul style="list-style-type: none"> <li>— forwards</li> <li>— Backwards</li> <li>— upwards</li> <li>— at the side</li> <li>— downwards</li> </ul> </li> <li>• for live parts <ul style="list-style-type: none"> <li>— forwards</li> <li>— Backwards</li> <li>— upwards</li> </ul> </li> </ul>	0 mm 0 mm 50 mm 50 mm 0 mm  0 mm 0 mm 50 mm 30 mm 50 mm  0 mm 0 mm 50 mm

- downwards
- at the side

50 mm

30 mm

### Connections/ Terminals:

<b>Product function</b> <ul style="list-style-type: none"> <li>• removable terminal for auxiliary and control circuit</li> </ul>	No
<b>Type of electrical connection</b> <ul style="list-style-type: none"> <li>• for main current circuit</li> <li>• for auxiliary and control current circuit</li> </ul>	screw-type terminals screw-type terminals
<b>Arrangement of electrical connectors for main current circuit</b>	Top and bottom
<b>Type of connectable conductor cross-sections</b> <ul style="list-style-type: none"> <li>• for main contacts               <ul style="list-style-type: none"> <li>— single or multi-stranded</li> <li>— finely stranded with core end processing</li> </ul> </li> <li>• at AWG conductors for main contacts</li> </ul>	2x (0,75 ... 2,5 mm <sup>2</sup> ), 2x 4 mm <sup>2</sup> 2x (0.5 ... 1.5 mm <sup>2</sup> ), 2x (0.75 ... 2.5 mm <sup>2</sup> ) 2x (18 ... 14), 2x 12
<b>Type of connectable conductor cross-sections</b> <ul style="list-style-type: none"> <li>• for auxiliary contacts               <ul style="list-style-type: none"> <li>— single or multi-stranded</li> <li>— finely stranded with core end processing</li> </ul> </li> <li>• at AWG conductors for auxiliary contacts</li> </ul>	2x (0,5 ... 1,5 mm <sup>2</sup> ), 2x (0,75 ... 2,5 mm <sup>2</sup> ) 2x (0.5 ... 1.5 mm <sup>2</sup> ), 2x (0.75 ... 2.5 mm <sup>2</sup> ) 2x (20 ... 16), 2x (18 ... 14)
<b>Tightening torque</b> <ul style="list-style-type: none"> <li>• for main contacts with screw-type terminals</li> <li>• for auxiliary contacts with screw-type terminals</li> </ul>	0.8 ... 1.2 N·m 0.8 ... 1.2 N·m
<b>Design of screwdriver shaft</b>	Diameter 5 to 6 mm
<b>Design of the thread of the connection screw</b> <ul style="list-style-type: none"> <li>• for main contacts</li> <li>• of the auxiliary and control contacts</li> </ul>	M3 M3

### Safety related data:

<b>B10 value</b> <ul style="list-style-type: none"> <li>• with high demand rate acc. to SN 31920</li> </ul>	50 000
<b>Proportion of dangerous failures</b> <ul style="list-style-type: none"> <li>• with low demand rate acc. to SN 31920</li> <li>• with high demand rate acc. to SN 31920</li> </ul>	40 % 40 %
<b>Failure rate [FIT]</b> <ul style="list-style-type: none"> <li>• with low demand rate acc. to SN 31920</li> </ul>	50 FIT
<b>T1 value for proof test interval or service life acc. to IEC 61508</b>	10 y
<b>Display version</b> <ul style="list-style-type: none"> <li>• for switching status</li> </ul>	Handle

### Certificates/approvals

General Product Approval	For use in hazardous locations
--------------------------	--------------------------------



[KTL](#)



For use in hazardous locations	Declaration of Conformity	Test Certificates	Shipping Approval
--------------------------------	---------------------------	-------------------	-------------------



[spezielle Prüfbescheinigung](#)  
[n](#)

[Typprüfbescheinigung/Werkszeugnis](#)



### Shipping Approval



other	Railway
-------	---------

[Bestätigungen](#)

[Umweltbestätigung](#)



[Schwingen/Schocke](#)  
[n](#)

### Further information

**Information- and Downloadcenter (Catalogs, Brochures,...)**

<http://www.siemens.com/industrial-controls/catalogs>

**Industry Mall (Online ordering system)**

<https://mall.industry.siemens.com/mall/en/en/Catalog/product?mlfb=3RV20114AA15>

**Cax online generator**

<http://support.automation.siemens.com/WW/CAXorder/default.aspx?lang=en&mlfb=3RV20114AA15>

**Service&Support (Manuals, Certificates, Characteristics, FAQs,...)**

<https://support.industry.siemens.com/cs/ww/en/ps/3RV20114AA15>

**Image database (product images, 2D dimension drawings, 3D models, device circuit diagrams, EPLAN macros, ...)**

[http://www.automation.siemens.com/bilddb/cax\\_de.aspx?mlfb=3RV20114AA15&lang=en](http://www.automation.siemens.com/bilddb/cax_de.aspx?mlfb=3RV20114AA15&lang=en)

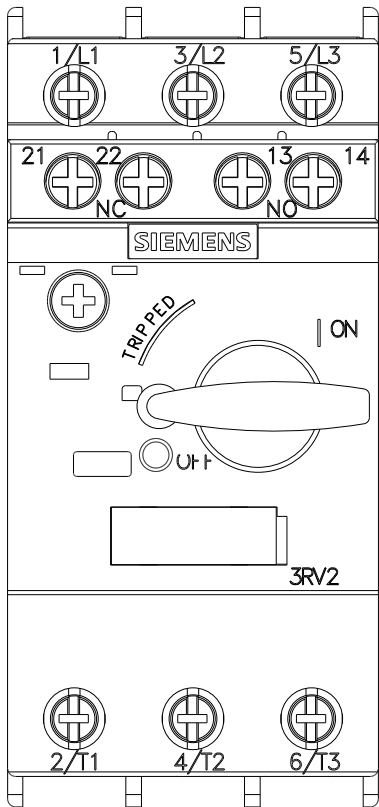
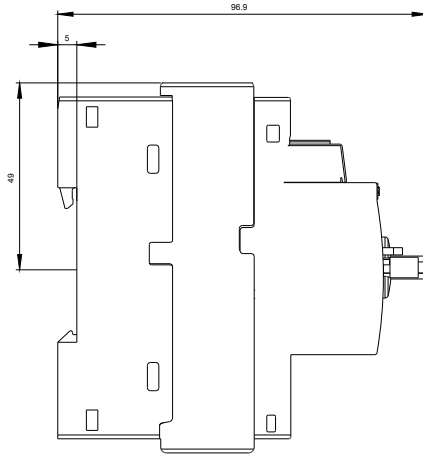
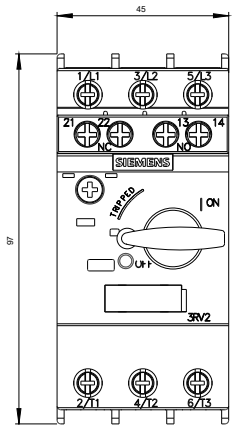

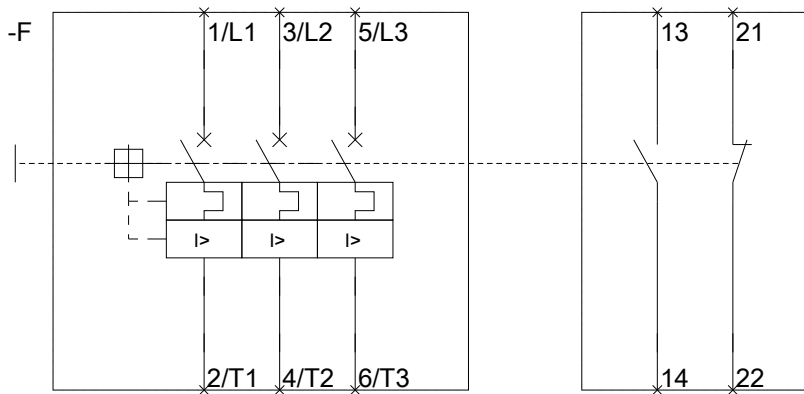

last modified:

09.04.2016