

BUSBAR SYSTEM, ACCESSORIES CENTER-  
CENTER DISTANCE 40.60 MM TERMINAL RAIL  
THICKNESS: 5 MM 4-35 SQMM



Model

product brand name SENTRON

General Product Approval	Declaration of Conformity	Test Certificates	Shipping Approval
--------------------------	---------------------------	-------------------	-------------------



[spezielle Prüfbescheinigung](#)  
n



Shipping Approval	other
-------------------	-------



[sonstig](#)

Further information

Information- and Downloadcenter (Catalogs, Brochures,...)  
<http://www.siemens.com/lowvoltage/catalogs>

**Industry Mall (Online ordering system)**

<https://eb.automation.siemens.com/mall/en/WW/Catalog/Product/8US19212AB01>

**Service&Support (Manuals, Certificates, Characteristics, FAQs,...)**

<http://support.automation.siemens.com/WW/view/en/8US19212AB01/all>

**Image database (product images, 2D dimension drawings, 3D models, device circuit diagrams, ...)**

[http://www.automation.siemens.com/bilddb/cax\\_en.aspx?mlfb=8US19212AB01](http://www.automation.siemens.com/bilddb/cax_en.aspx?mlfb=8US19212AB01)

**CAX-Online-Generator**

<http://www.siemens.com/cax>

**Tender specifications**

<http://ausschreibungstexte.siemens.com/tiplv>

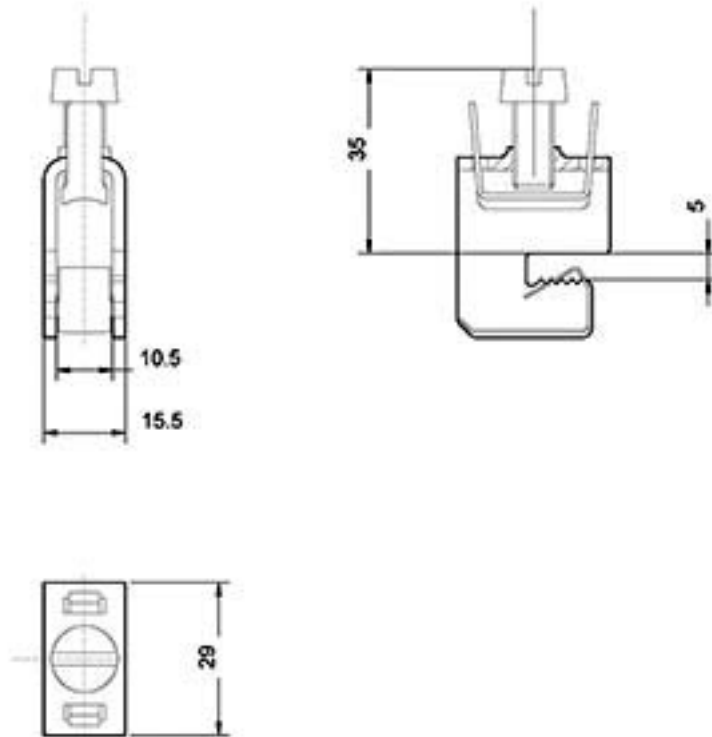

last modified:

23.10.2015