



CIRCUIT-BREAKER SZ S00, FOR MOTOR PROTECTION, CLASS 10, A-REL. 0.9...1.25A, N-RELEASE16A, SCREW CONNECTION, STANDARD SW. CAPACITY W. TRANSVERSE AUX. SWITCH 1NO+1NC

product brand name	SIRIUS
Product designation	3RV2 circuit breaker

General technical data:

Active power loss total typical	6 W
Insulation voltage	690 V
<ul style="list-style-type: none"> with degree of pollution 3 Rated value 	
Surge voltage resistance Rated value	6 kV
Mechanical service life (switching cycles)	
<ul style="list-style-type: none"> of the main contacts typical of the auxiliary contacts typical 	100 000 100 000
Electrical endurance (switching cycles)	
<ul style="list-style-type: none"> typical 	100 000
Temperature compensation	-20 ... +60 °C
Size of contactor can be combined company-specific	S0
Protection class IP	
<ul style="list-style-type: none"> on the front of the terminal 	IP20 IP20
Type of protection	Increased safety
Equipment marking	
<ul style="list-style-type: none"> acc. to DIN EN 81346-2 	Q

Main circuit:

Number of poles for main current circuit	3
Adjustable response value current of the current-dependent overload release	0.9 ... 1.25 A
Operating voltage	

<ul style="list-style-type: none"> • Rated value 	690 V
<ul style="list-style-type: none"> • at AC-3 Rated value maximum 	690 V
Operating frequency Rated value	50 ... 60 Hz
Operating current Rated value	1.25 A
Operating current	
<ul style="list-style-type: none"> • at AC-3 — at 400 V Rated value 	1.25 A
Operating frequency	
<ul style="list-style-type: none"> • at AC-3 maximum 	15 1/h

Auxiliary circuit:

Number of NC contacts	
<ul style="list-style-type: none"> • for auxiliary contacts 	1
Number of NO contacts	
<ul style="list-style-type: none"> • for auxiliary contacts 	1
Number of CO contacts	
<ul style="list-style-type: none"> • for auxiliary contacts 	0
Product expansion Auxiliary switch	Yes
Design of the auxiliary switch	transverse
Operating current of the auxiliary contacts at AC-15	
<ul style="list-style-type: none"> • at 24 V • at 120 V • at 125 V • at 230 V 	2 A 0.5 A 0.5 A 0.5 A
Operating current of the auxiliary contacts at DC-13	
<ul style="list-style-type: none"> • at 24 V • at 60 V 	1 A 0.15 A

Protective and monitoring functions:

Trip class	CLASS 10
Design of the overload circuit breaker	thermal
Operational short-circuit current breaking capacity (Ics) with AC	
<ul style="list-style-type: none"> • at 240 V Rated value • at 400 V Rated value • at 500 V Rated value • at 690 V Rated value 	100 kA 100 kA 100 kA 100 kA
Maximum short-circuit current breaking capacity (Icu)	
<ul style="list-style-type: none"> • with AC at 240 V Rated value • with AC at 400 V Rated value • with AC at 500 V Rated value • with AC at 690 V Rated value 	100 kA 100 kA 100 kA 100 kA
Breaking capacity short-circuit current (Icn)	

<ul style="list-style-type: none"> • with 1 current path for DC at 150 V Rated value 	10 kA
<ul style="list-style-type: none"> • with 2 current paths in series for DC at 300 V Rated value 	10 kA
<ul style="list-style-type: none"> • with 3 current paths in series for DC at 450 V Rated value 	10 kA
Response value current of the instantaneous short-circuit release	16 A

UL/CSA ratings:

Full-load current (FLA) for three-phase AC motor	
<ul style="list-style-type: none"> • at 480 V Rated value 	1.25 A
<ul style="list-style-type: none"> • at 600 V Rated value 	1.25 A
Contact rating of the auxiliary contacts acc. to UL	C300 / R300

Short-circuit:

Design of the short-circuit trip	magnetic
Design of the fuse link	
<ul style="list-style-type: none"> • for short-circuit protection of the auxiliary switch required 	Fuse gL/gG: 10 A, miniature circuit breaker C 6 A (short-circuit current $I_k < 400$ A)
Design of the fuse link for IT network for short-circuit protection of the main circuit	
<ul style="list-style-type: none"> • at 500 V 	gL/gG 16 A
<ul style="list-style-type: none"> • at 690 V 	gL/gG 16 A

Installation/ mounting/ dimensions:

mounting position	any
Mounting type	screw and snap-on mounting onto 35 mm standard mounting rail according to DIN EN 60715
Height	97 mm
Width	45 mm
Depth	96 mm
Required spacing	
<ul style="list-style-type: none"> • with side-by-side mounting <ul style="list-style-type: none"> — forwards — Backwards — upwards — downwards — at the side • for grounded parts <ul style="list-style-type: none"> — forwards — Backwards — upwards — at the side — downwards • for live parts 	0 mm 0 mm 50 mm 50 mm 0 mm 0 mm 0 mm 50 mm 30 mm 50 mm

— forwards	0 mm
— Backwards	0 mm
— upwards	50 mm
— downwards	50 mm
— at the side	30 mm

Connections/ Terminals:

Product function	
<ul style="list-style-type: none"> removable terminal for auxiliary and control circuit 	No
Type of electrical connection	
<ul style="list-style-type: none"> for main current circuit for auxiliary and control current circuit 	screw-type terminals screw-type terminals
Arrangement of electrical connectors for main current circuit	Top and bottom
Type of connectable conductor cross-section	
<ul style="list-style-type: none"> for main contacts <ul style="list-style-type: none"> single or multi-stranded finely stranded with core end processing for AWG conductors for main contacts for auxiliary contacts <ul style="list-style-type: none"> single or multi-stranded finely stranded with core end processing for AWG conductors for auxiliary contacts 	2x (0,75 ... 2,5 mm ²), 2x 4 mm ² 2x (0.5 ... 1.5 mm ²), 2x (0.75 ... 2.5 mm ²) 2x (18 ... 14), 2x 12 2x (0,5 ... 1,5 mm ²), 2x (0,75 ... 2,5 mm ²) 2x (0.5 ... 1.5 mm ²), 2x (0.75 ... 2.5 mm ²) 2x (20 ... 16), 2x (18 ... 14)
Design of screwdriver shaft	Diameter 5 to 6 mm
Design of the thread of the connection screw	
<ul style="list-style-type: none"> for main contacts of the auxiliary and control contacts 	M3 M3

Safety related data:

B10 value with high demand rate acc. to SN 31920	50 000
Proportion of dangerous failures	
<ul style="list-style-type: none"> with low demand rate acc. to SN 31920 with high demand rate acc. to SN 31920 	40 % 40 %
T1 value for proof test interval or service life acc. to IEC 61508	10 y
Protection against electrical shock	finger-safe

Mechanical data:

Size of the circuit-breaker	S00
------------------------------------	-----

Ambient conditions:

Installation altitude at height above sea level maximum	2 000 m
Ambient temperature	

- during operation
- during storage
- during transport

-20 ... +60 °C

-50 ... +80 °C

-50 ... +80 °C

Relative humidity during operation

10 ... 95 %

Display:

Display version

- for switching status

Handle

Certificates/ approvals:

General Product Approval

For use in hazardous locations



CCC



CSA



UL

[KTL](#)



ATEX

Declaration of Conformity



EG-Konf.

Test Certificates

[Type Test Certificates/Test Report](#)

[Special Test Certificate](#)

[Declaration of the Compliance with the order](#)

Shipping Approval



ABS



BUREAU VERITAS

Shipping Approval



DNV



GL



LRS



PRS



RINA



RMRS

other

[Environmental Confirmations](#)

[Confirmation](#)



VDE

[other](#)

Further information

Information- and Downloadcenter (Catalogs, Brochures,...)

<http://www.siemens.com/industrial-controls/catalogs>

Industry Mall (Online ordering system)

<http://www.siemens.com/industrymall>

Cax online generator

<http://support.automation.siemens.com/WW/CAXorder/default.aspx?lang=en&mlfb=3RV20110KA15>

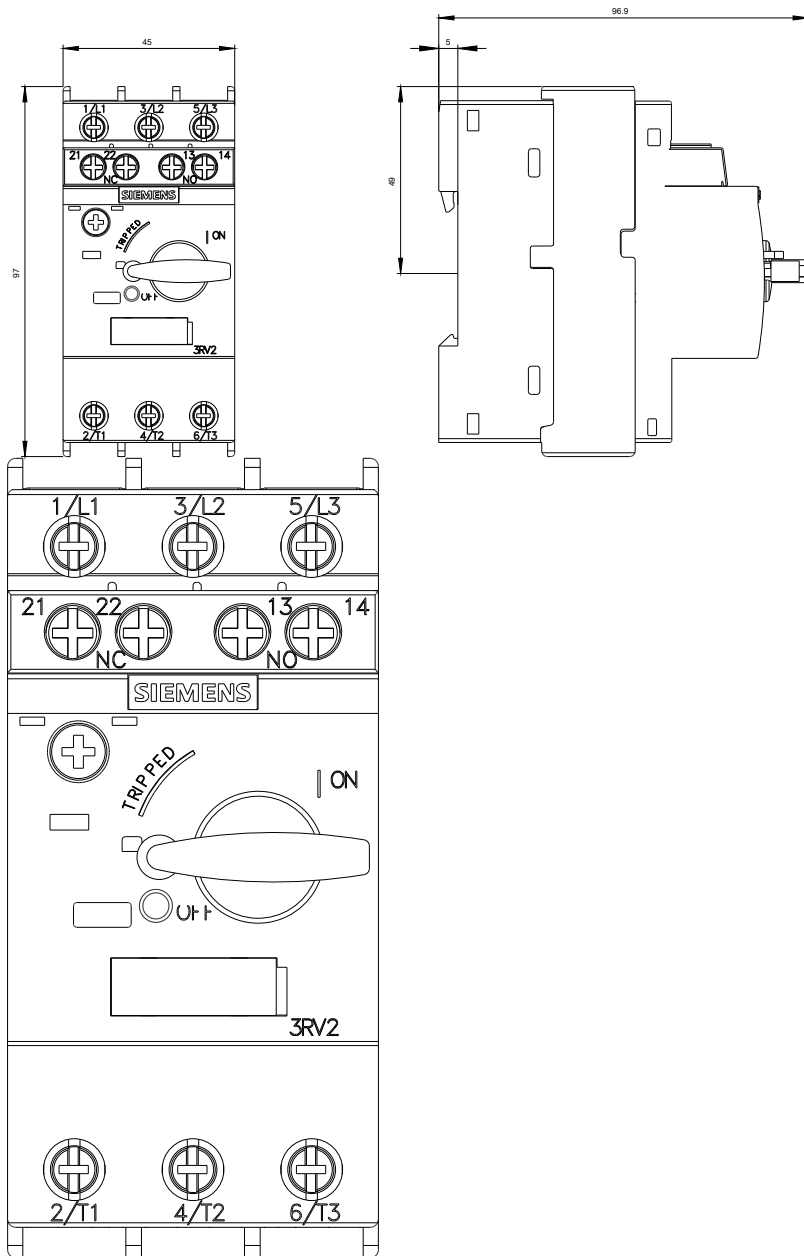

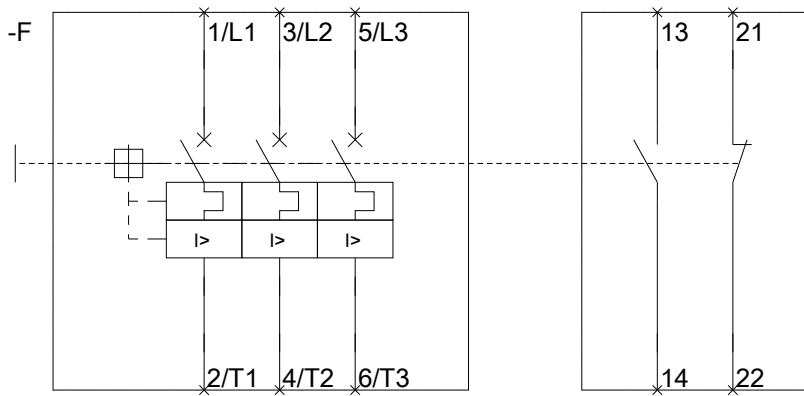

last modified:

14.05.2015