



SIRIUS POSITION SWITCH METAL ENCLOSURE 40MM TO EN50041 DEVICE CONNECTION 1X (M20X1.5) 1NO/ 2NC SLOW-ACTION CONTACTS ROTARY ACTUATOR RIGHT/LEFT ADJUSTABLE, METAL LEVER 27MM LONG AND PLASTIC ROLLER 19MM

**Manufacturer article number**

- of the basic unit included in the scope of supply
- of the actuator head for position switches included in the scope of supply
- of the operating lever included in the scope of supply

[3SE5112-0KA00](#)

[3SE5000-0AH00](#)

[3SE5000-0AA01](#)

**General technical data:**

<b>Product designation</b>		standard position switch
<b>Explosion protection category for dust</b>		none
<b>Insulation voltage</b>		
• rated value	V	400
<b>Degree of pollution</b>		class 3
<b>Thermal current</b>	A	6
<b>Operating current</b>		
• at AC-15		
• at 24 V / rated value	A	6
• at 125 V / rated value	A	6
• at 230 V / rated value	A	1.5
• at DC-13		
• at 24 V / rated value	A	3
• at 125 V / rated value	A	0.55
• at 230 V / rated value	A	0.27

<b>Continuous current</b>		
• of the slow DIAZED fuse link	A	6
• of the quick DIAZED fuse link	A	10
• of the C characteristic circuit breaker	A	1
<b>Mechanical operating cycles as operating time</b>		
• typical		15,000,000
<b>Electrical operating cycles as operating time</b>		
• with contactor 3RH11, 3RT1016, 3RT1017, 3RT1024, 3RT1025, 3RT1026 / typical		10,000,000
• at AC-15 / at 230 V / typical		100,000
<b>Electrical operating cycles in one hour</b>		
• with contactor 3RH11, 3RT1016, 3RT1017, 3RT1024, 3RT1025, 3RT1026		6,000
<b>Repeat accuracy</b>	mm	0.05
<b>Design of the contact element</b>		slow-action contacts
<b>Number of NC contacts</b>		
• for auxiliary contacts		2
<b>Design of the switching function</b>		positive opening
<b>Number of NO contacts</b>		
• for auxiliary contacts		1
<b>Resistance against vibration</b>		0.35 mm / 5g
<b>Resistance against shock</b>		30g / 11 ms
<b>Ambient temperature</b>		
• during operating	°C	-25 ... +85
• during storage	°C	-40 ... +90
<b>Product specification</b>		
• for dimensions		EN 50041
<b>Width of the sensor</b>	mm	40
<b>Material</b>		
• of the enclosure		metal
<b>Material / of the enclosure / of the switch head</b>		metal
<b>Design of the operating mechanism</b>		metal lever, 27 mm long, step 9 mm, plastic roller 19 mm
<b>Actuating speed</b>	mm/s / m/s	0.4 ... 1.5
<b>Minimum actuating force / in activation direction</b>	N·m	0.25
<b>Protection class IP</b>		IP66/IP67
<b>mounting position</b>		any
<b>Cable gland version</b>		1x (M20 x 1.5)
<b>Design of the electrical connection</b>		screw-type terminals
<b>Reference code</b>		

- according to DIN 40719 extended according to IEC 204-2
- according to DIN EN 61346-2

	S
	B

### Certificates/ approvals:

General Product Approval	Declaration of Conformity	Test Certificates	other
 CSA	 EAC	 UL	 EG-Konf.
		<a href="#">Special Test Certificate</a>	<a href="#">Confirmation</a>

### Further information:

#### Information- and Downloadcenter (Catalogs, Brochures,...)

<http://www.siemens.com/industrial-controls/catalogs>

#### Industry Mall (Online ordering system)

<http://www.siemens.com/industrymall>

#### Cax online generator

<http://www.siemens.com/cax>

#### Service&Support (Manuals, Certificates, Characteristics, FAQs,...)

<http://support.automation.siemens.com/WW/view/en/3SE5112-0KH01/all>

#### Image database (product images, 2D dimension drawings, 3D models, device circuit diagrams, ...)

[http://www.automation.siemens.com/bilddb/cax\\_en.aspx?mlfb=3SE5112-0KH01](http://www.automation.siemens.com/bilddb/cax_en.aspx?mlfb=3SE5112-0KH01)

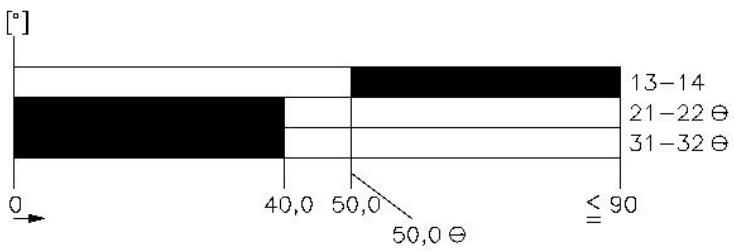
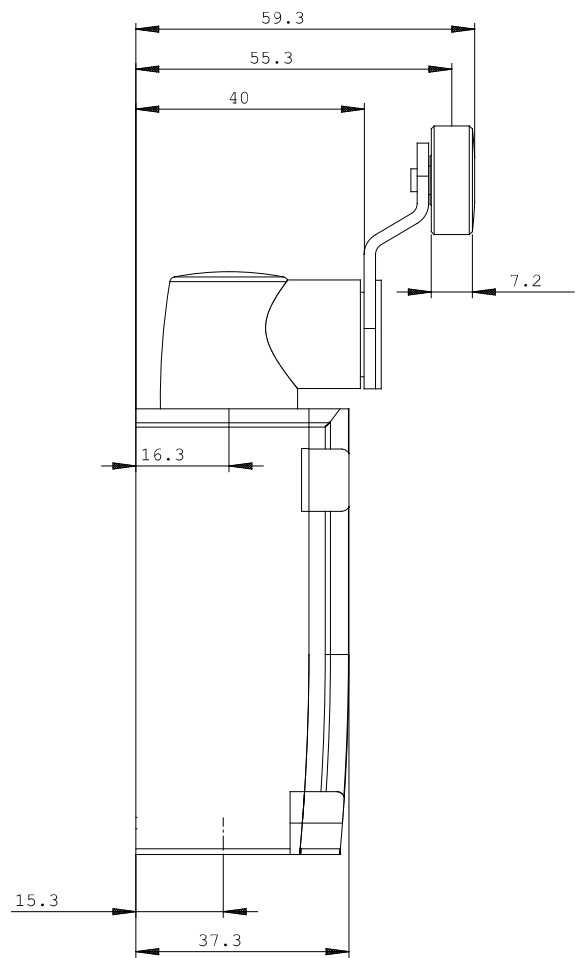
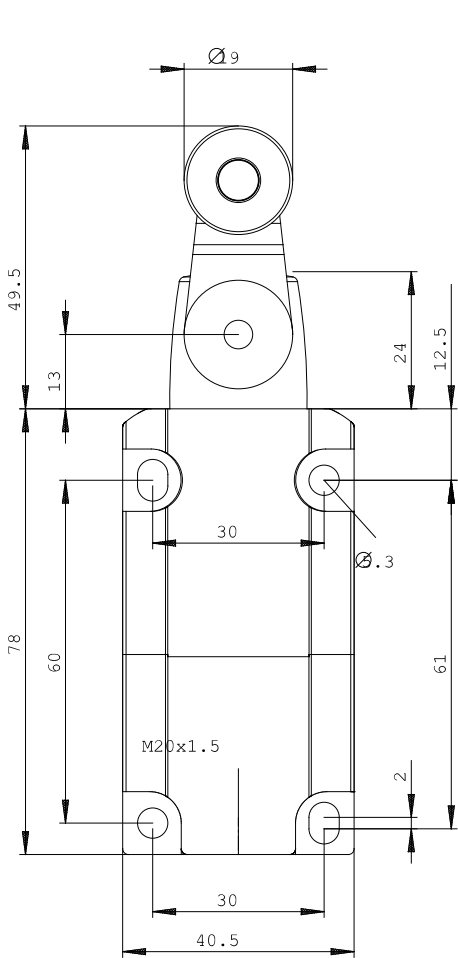

last change:

Jul 24, 2014