

Fitting the Brake Modules (PM240 / PM250 / PM260)

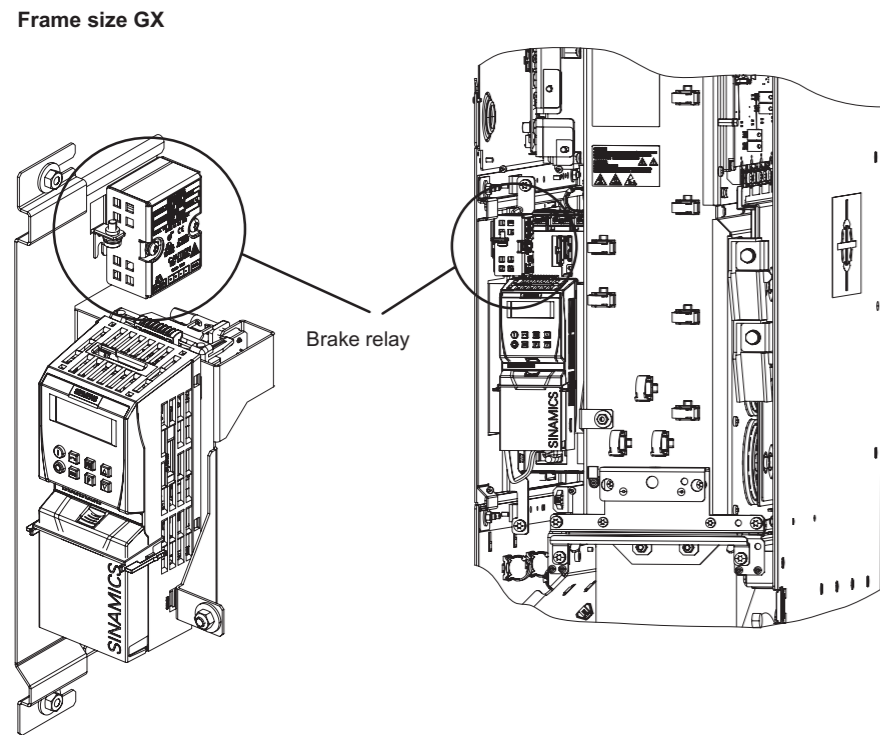

Fitting the Brake Modules (PM240-2 / PM240P-2 / PM250)

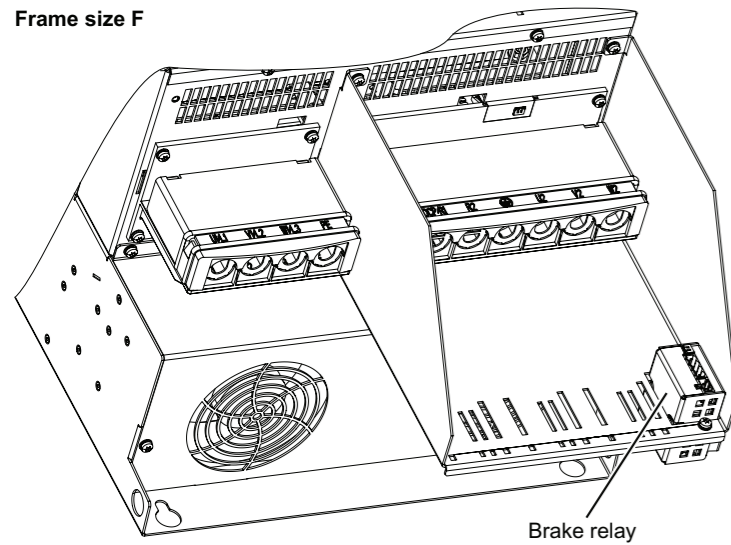
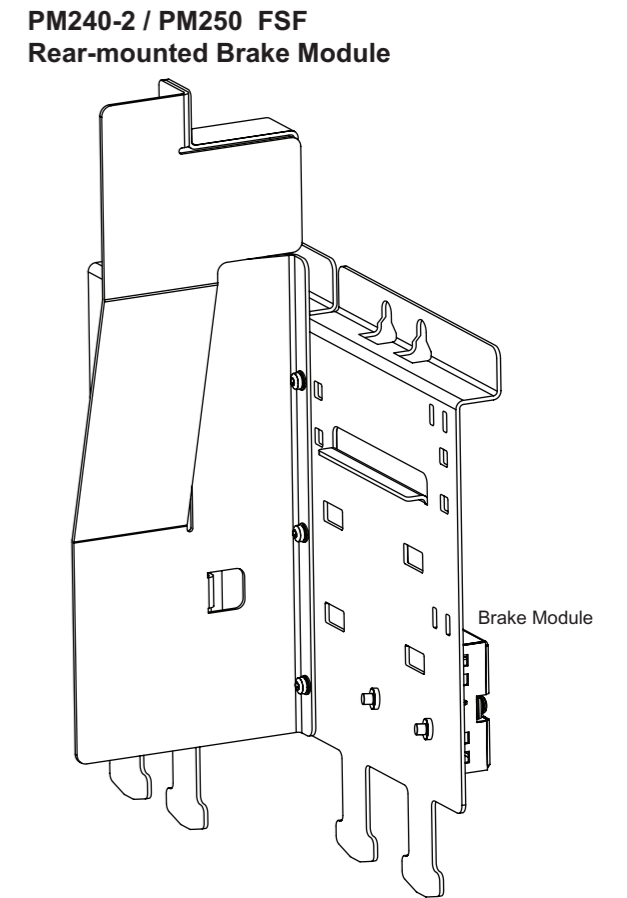
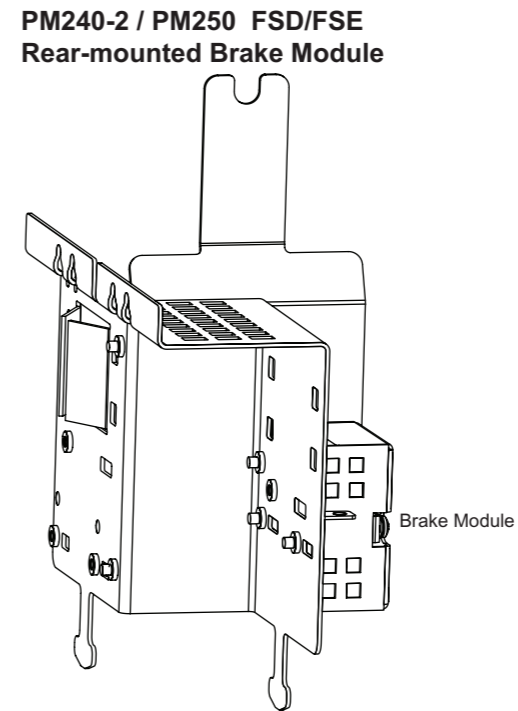
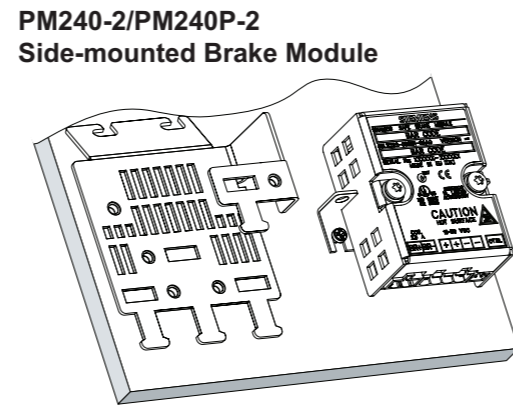

Connection diagrams

Safe Brake Relay (with 24 V DC external supply)

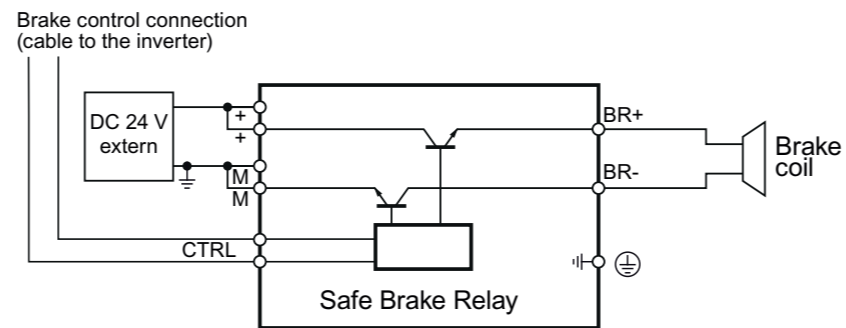

Brake Relay (with 24 V DC external supply)

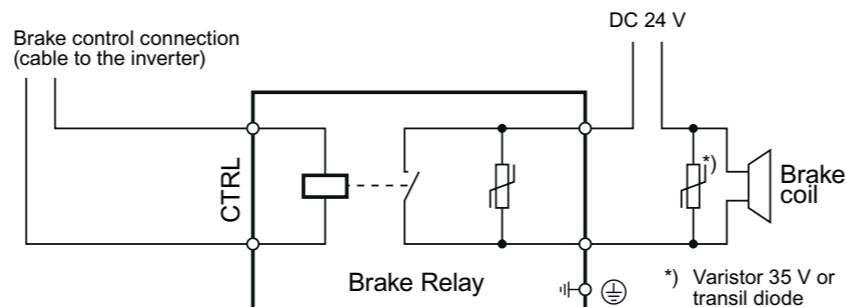

Brake Relay (with 230 V AC or 400 V AC supply)

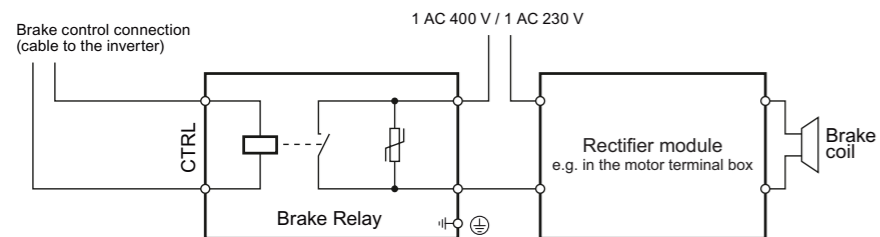

Mean time to failure when controlling Siemens brake is 500,000 operations.  
Mit Siemens-Bremsen werden im Mittel 500 000 störungsfreie Schaltvorgänge erreicht.

Dimensions

Brake Relay Module

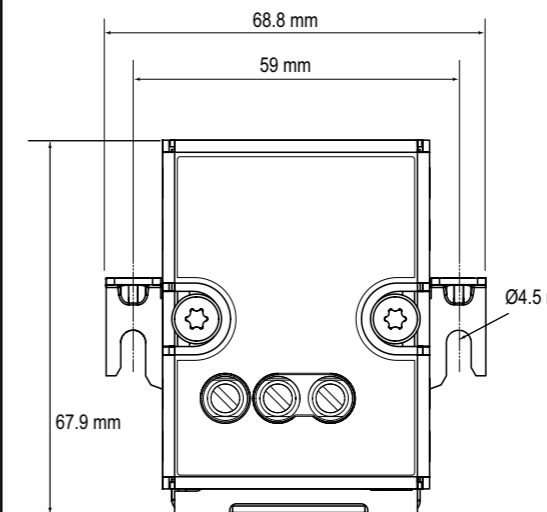
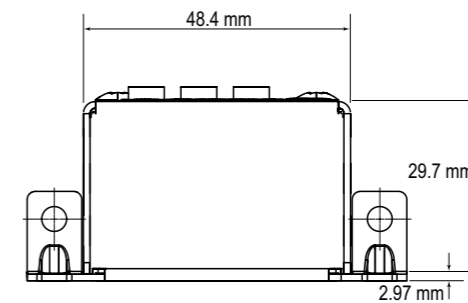

Safe Brake Relay Module

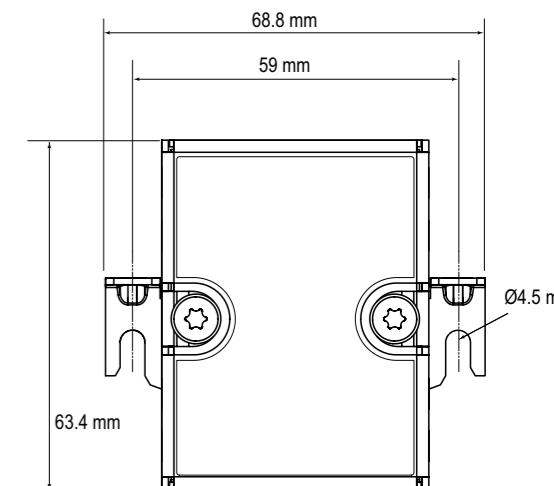
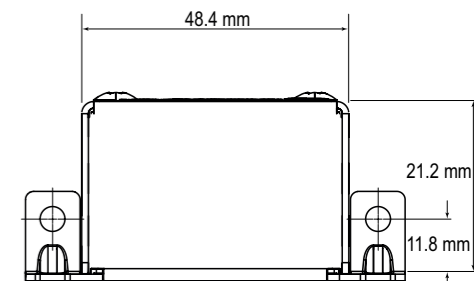



**Warning**

**Danger to life if the safety instructions and installation instructions are not observed**

The compact hardware installation instructions only contain the most important information for installing the Brake Relay.

If the safety instructions and installation instructions of the Power Module in the associated documentation are not observed, accidents involving severe injuries or death can occur.

- Observe the safety instructions and installation instructions given in the associated documentation.

See also <http://support.automation.siemens.com/WW/view/en/30563173/133300> or use the QR Code on the right.



**Note**

- Both Brake relays are fitted to the Termination Screening Kit in the same way. For assembly details, please refer to the diagrams below.
- For use with Siemens motor brakes. See diagrams for connection details.

**Hinweis**

- Beide Brake relays werden auf die selbe Weise in den Schirmanschlusssatz eingesetzt. Einzelheiten zur Montage können der untenstehenden Grafik entnommen werden.
- Zum Einsatz mit Siemens-Motor-Bremsen. Details zum Anschließen, siehe Diagramm.

**Brake Relay** 6SL3252-0BB00-0AA0  
**Safe Brake Relay** 6SL3252-0BB01-0AA0

**Brake Relay description**

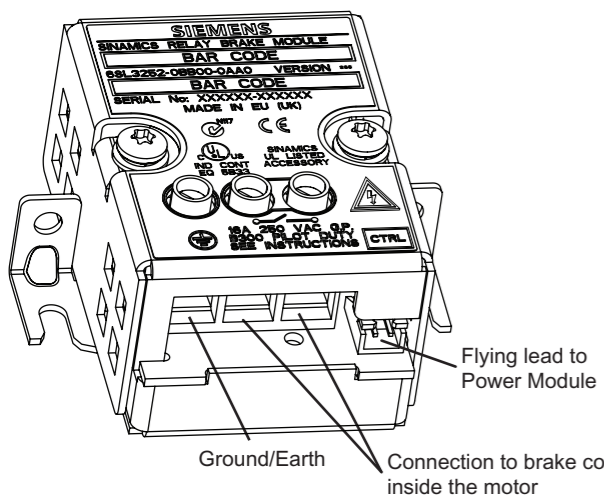

UL approved applications  
Ratings:  
16 A 250 V AC General purpose  
10 FLA 250 V AC Motor rated  
4.5 FLA 480 V AC Motor rated  
B 300 Pilot duty  
1 A 24 V DC

Non UL approved applications:  
Ratings:  
12 A 24 V DC Resistive loads only  
7 A 30 V DC Resistive loads only

**Safe Brake Relay description**

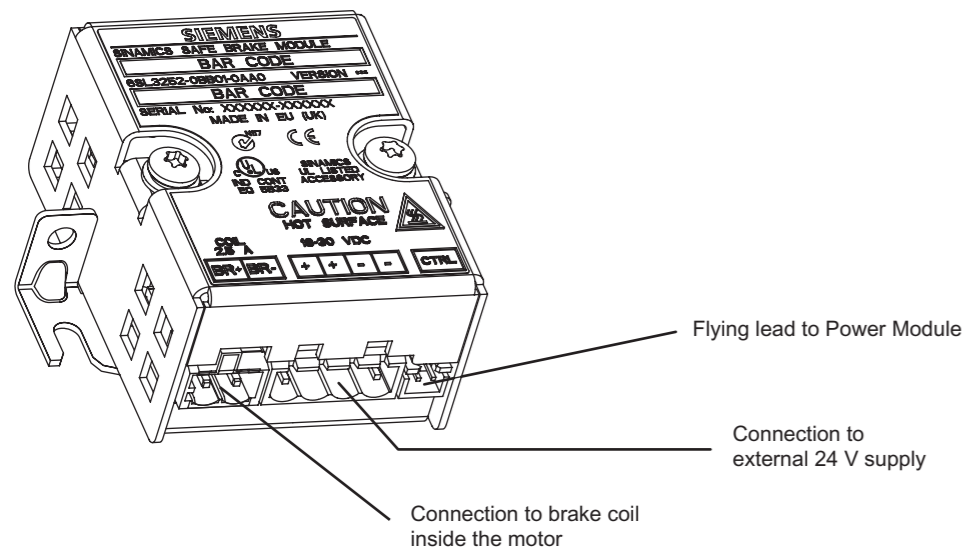

**Fitting the Brake Modules (PM240 / PM250 / PM260)**

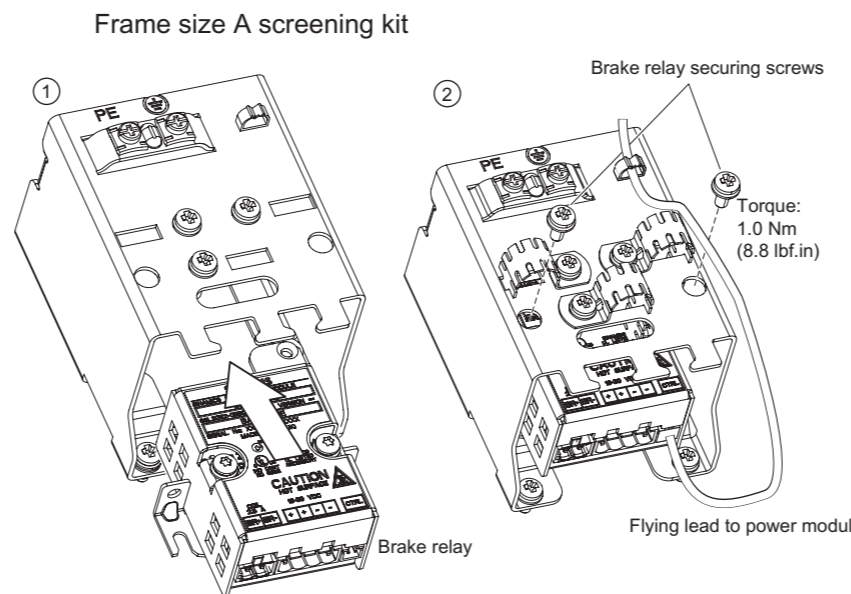

**Frame size D and E**

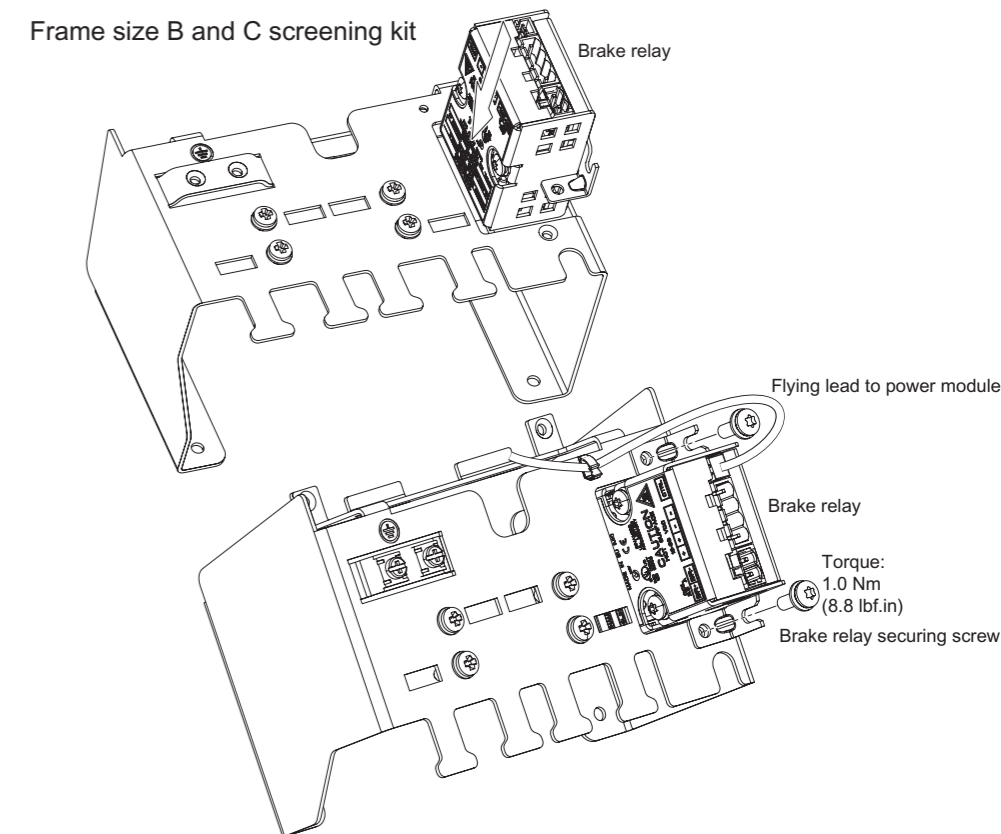
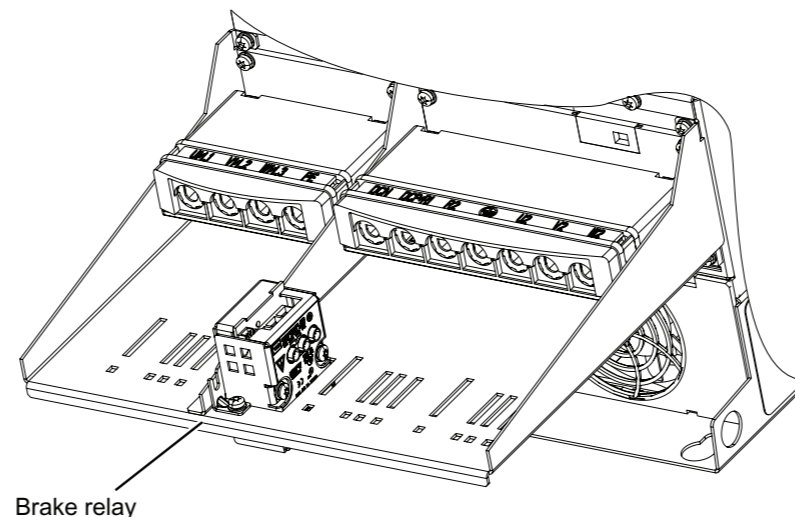

Technische Änderungen vorbehalten  
Subject to change without prior notice  
© Siemens AG 2017

March 2017

Printed in the United Kingdom

A5E02344645A AF



A 5 E 0 2 3 4 4 6 4 5 A