



SIRIUS soft starter S00 17.6 A, 7.5 kW/400 V, 40 °C 200-480 V AC, 110-230 V AC/DC Screw terminals

General technical data

product brand name		SIRIUS
product feature		
• integrated bypass contact system		Yes
• thyristors		Yes
product function		
• intrinsic device protection		No
• motor overload protection		No
• evaluation of thermistor motor protection		No
• external reset		No
• adjustable current limitation		No
• inside-delta circuit		No
product component motor brake output		No
insulation voltage rated value	V	600
degree of pollution		3, acc. to IEC 60947-4-2
reference code according to EN 61346-2		Q
reference code according to DIN 40719 extended according to IEC 204-2 according to IEC 750		G

Power Electronics

product designation		Soft starter
operational current		
• at 40 °C rated value	A	17.6
• at 50 °C rated value	A	17
• at 60 °C rated value	A	14
yielded mechanical performance for 3-phase motors		
• at 230 V		
— at standard circuit at 40 °C rated value	kW	4
• at 400 V		
— at standard circuit at 40 °C rated value	kW	7.5
yielded mechanical performance [hp] for 3-phase AC motor at 200/208 V at standard circuit at 50 °C rated value	hp	3
operating frequency rated value	Hz	50 ... 60
relative negative tolerance of the operating frequency	%	-10
relative positive tolerance of the operating frequency	%	10
operating voltage at standard circuit rated value	V	200 ... 480
relative negative tolerance of the operating voltage at standard circuit	%	-15
relative positive tolerance of the operating voltage at standard circuit	%	10
minimum load [%]	%	10
continuous operating current [% of I_e] at 40 °C	%	115
power loss [W] at operational current at 40 °C during	W	4

operation typical

Control circuit/ Control

type of voltage of the control supply voltage		AC/DC
control supply voltage frequency 1 rated value	Hz	50
control supply voltage frequency 2 rated value	Hz	60
relative negative tolerance of the control supply voltage frequency	%	-10
relative positive tolerance of the control supply voltage frequency	%	10
control supply voltage 1 at AC at 50 Hz	V	110 ... 230
control supply voltage 1 at AC at 60 Hz	V	110 ... 230
relative negative tolerance of the control supply voltage at AC at 50 Hz	%	-15
relative positive tolerance of the control supply voltage at AC at 50 Hz	%	10
relative negative tolerance of the control supply voltage at AC at 60 Hz	%	-15
relative positive tolerance of the control supply voltage at AC at 60 Hz	%	10
control supply voltage 1 at DC	V	110 ... 230
relative negative tolerance of the control supply voltage at DC	%	-20
relative positive tolerance of the control supply voltage at DC	%	20
display version for fault signal		red

Mechanical data

size of engine control device		S00
width	mm	45
height	mm	95
depth	mm	150
fastening method		screw and snap-on mounting
mounting position		With vertical mounting surface +/-10° rotatable, with vertical mounting surface +/- 10° tiltable to the front and back
required spacing with side-by-side mounting		
• upwards	mm	60
• at the side	mm	15
• downwards	mm	40
wire length maximum	m	300
number of poles for main current circuit		3

Connections/ Terminals

type of electrical connection		
• for main current circuit		screw-type terminals
• for auxiliary and control circuit		screw-type terminals
number of NC contacts for auxiliary contacts		0
number of NO contacts for auxiliary contacts		1
number of CO contacts for auxiliary contacts		0
type of connectable conductor cross-sections for main contacts for box terminal using the front clamping point		
• solid		2x (1 ... 2.5 mm ²), 2x (2.5 ... 6 mm ²)
• finely stranded with core end processing		2x (1 ... 2.5 mm ²), 2x (2.5 ... 6 mm ²)
type of connectable conductor cross-sections at AWG cables for main contacts for box terminal		
• using the front clamping point		2x (16 ... 10)
type of connectable conductor cross-sections for auxiliary contacts		
• solid		2x (0.25 ... 2.5 mm ²)
• finely stranded with core end processing		2x (0.25 ... 1.5 mm ²)
type of connectable conductor cross-sections at AWG cables		
• for auxiliary contacts		2x (20 ... 14)
• for auxiliary contacts finely stranded with core end processing		2x (20 ... 16)

Ambient conditions

installation altitude at height above sea level	m	5 000
---	---	-------

environmental category

- during transport according to IEC 60721
- during storage according to IEC 60721
- during operation according to IEC 60721

ambient temperature

- during operation
- during storage

derating temperature

protection class IP on the front according to IEC 60529

touch protection on the front according to IEC 60529

	2K2, 2C1, 2S1, 2M2 (max. fall height 0.3 m)
	1K6 (only occasional condensation), 1C2 (no salt mist), 1S2 (sand must not get inside the devices), 1M4
	3K6 (no formation of ice, no condensation), 3C3 (no salt mist), 3S2 (sand must not get into the devices), 3M6
°C	-25 ... +60
°C	-40 ... +80
°C	40
	IP20
	finger-safe, for vertical contact from the front

Certificates/ approvals

General Product Approval

EMC

[Confirmation](#)

EAC



Declaration of Conformity

Test Certificates

other



EG-Konf.

[Type Test Certificates/Test Report](#)[Miscellaneous](#)[Confirmation](#)**UL/CSA ratings**

yielded mechanical performance [hp] for 3-phase AC motor

- at 220/230 V
 - at standard circuit at 50 °C rated value
- at 460/480 V
 - at standard circuit at 50 °C rated value

hp	3
hp	10
	B300 / R300

contact rating of auxiliary contacts according to UL

Further information

Simulation Tool for Soft Starters (STS)

<https://support.industry.siemens.com/cs/ww/en/view/101494917>

Information- and Downloadcenter (Catalogs, Brochures,...)

<https://www.siemens.com/ic10>

Industry Mall (Online ordering system)

<https://mall.industry.siemens.com/mall/en/en/Catalog/product?mlfb=3RW3018-1BB14>

Cax online generator

<http://support.automation.siemens.com/WW/CAXorder/default.aspx?lang=en&mlfb=3RW3018-1BB14>

Service&Support (Manuals, Certificates, Characteristics, FAQs,...)

<https://support.industry.siemens.com/cs/ww/en/ps/3RW3018-1BB14>

Image database (product images, 2D dimension drawings, 3D models, device circuit diagrams, EPLAN macros, ...)

http://www.automation.siemens.com/bilddb/cax_de.aspx?mlfb=3RW3018-1BB14&lang=en

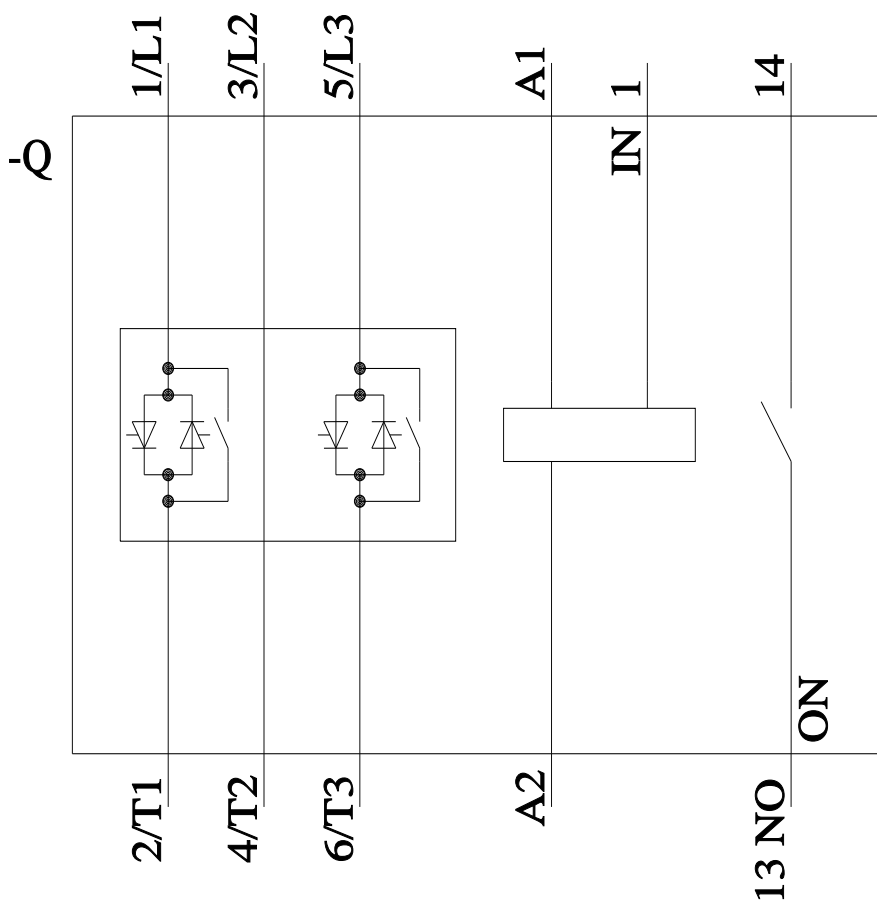
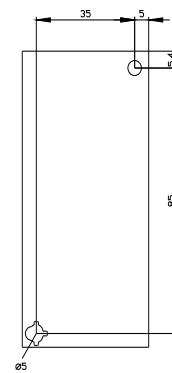
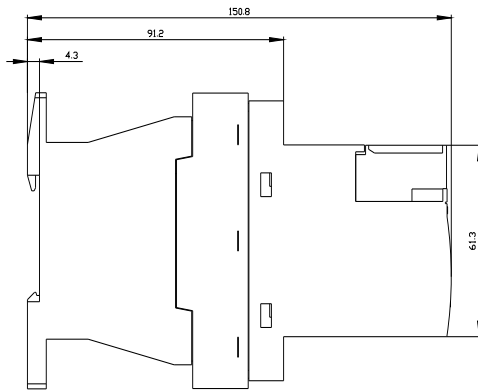
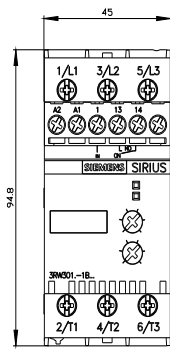

last modified:

10/28/2022