

SIRIUS

3RP25

DE	Elektronisches Zeitrelais Originalbetriebsanleitung	EL	Ηλεκτρονικός ηλεκτρονόμος καθυστέρησης Πρωτότυπες οδηγίες χρήσης	PL	Elektroniczny przekaźnik czasowy Oryginalna instrukcja obsługi
EN	Electronic timing relay Original Operating Instructions	ET	Elektroniline ajarelee Originaal-kasutusjuhend	RO	Releu de timp electronic Instrucțiuni originale de utilizare
FR	Relais électronique temporisé Instructions de service originales	FI	Elektroninen aikarele Alkuperäinen käyttöohje	SK	Elektronické časové relé Originálny návod na obsluhu
ES	Relés electrónicos de tiempo Instructivo original	HR	Elektronički vremenski relej Originalne upute za uporabu	SL	Elektronski časovni rele Originalno navodilo za obratovanje
IT	Relè elettronici a tempo Istruzioni operative originali	HU	Elektronikus időrelé Eredeti üzemeltetési útmutató	SV	Elektroniskt tidsrelä Originalbruksanvisning
PT	Relés temporizador eletrónicos Instruções de Serviço Originais	LT	Elektroninė laiko relė Originali eksploatacijos instrukcija	TR	Elektronik zaman rölesi Orijinal İşletme Kılavuzu
BG	Електронно времево реле Оригинално ръководство за експлоатация	LV	Elektronisks laika relejs Originālā lietošanas pamācība	PY	Электронное реле времени Оригинальное руководство по эксплуатации
CS	Elektronické časové relé Originální návod k obsluze	NL	Elektronisch tijdrelais Originele handleiding	中文	电子时间继电器 原始操作说明
DA	Elektronisk tidsrelæ Original brugsanvisning				

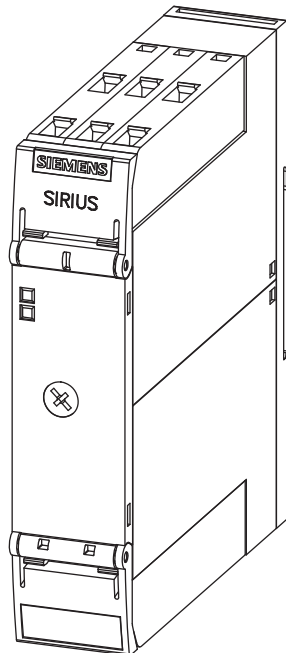

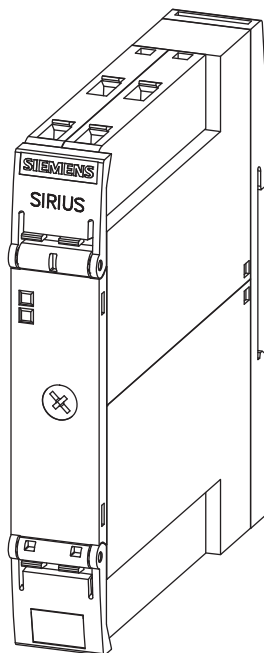
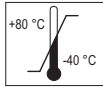
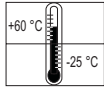







SIEMENS AG Telephone: +49 (911) 895-5900 (8⁰⁰ - 17⁰⁰ CET)
 Technical Assistance Fax: +49 (911) 895-5907
 Breslauer Str. 5 E-mail: technical-assistance@siemens.com
 D-90766 Fürth Internet: www.siemens.com/sirius/technical-assistance



<http://support.industry.siemens.com>
3ZX1012-0RP25-1AC1





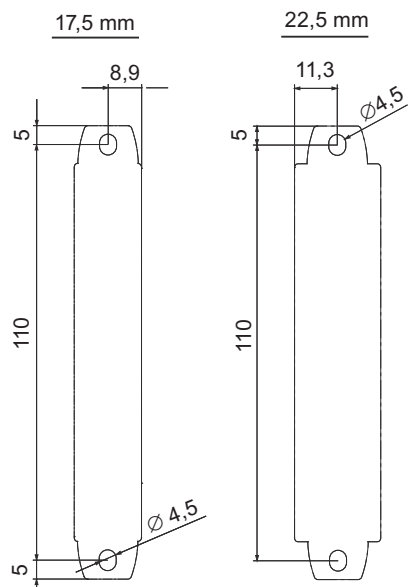
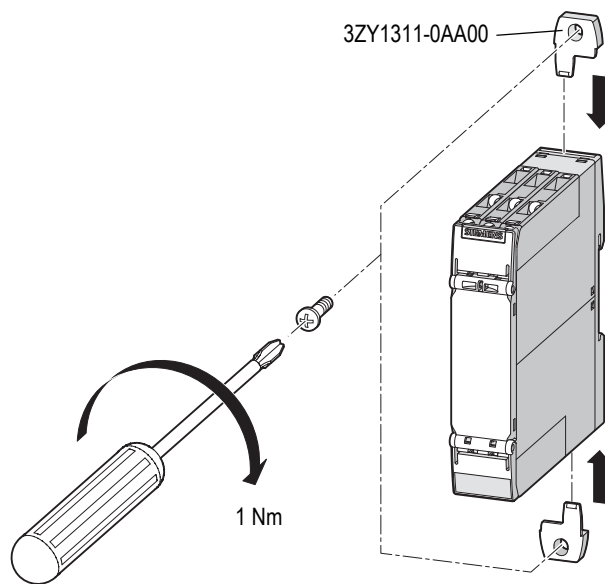
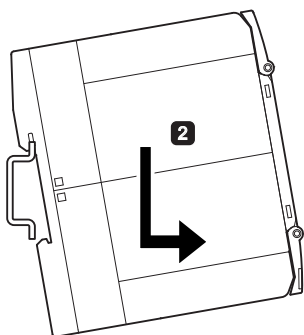
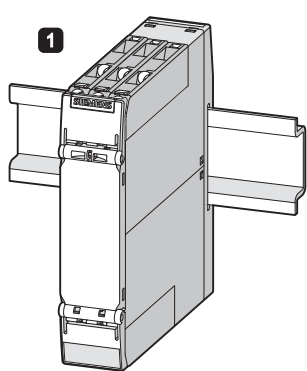
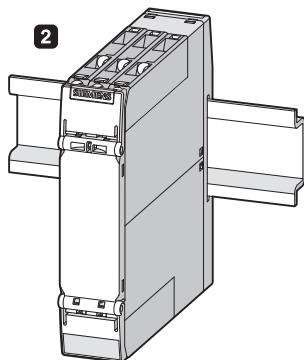
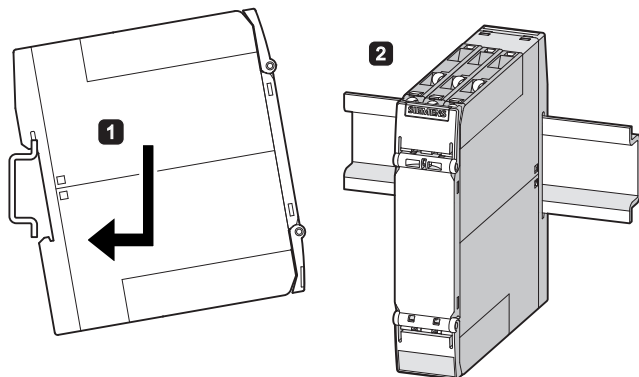
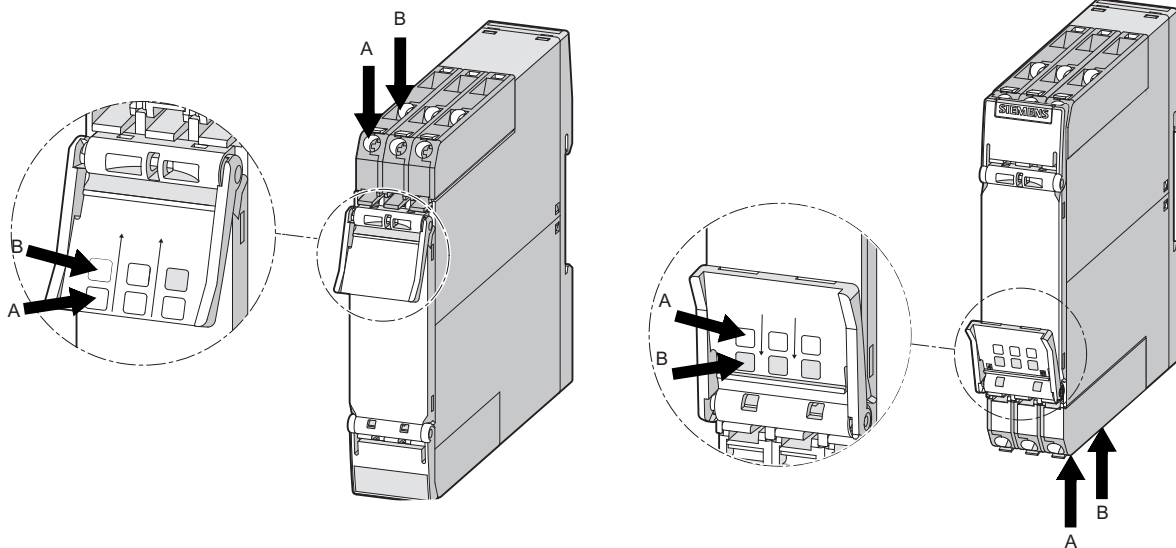

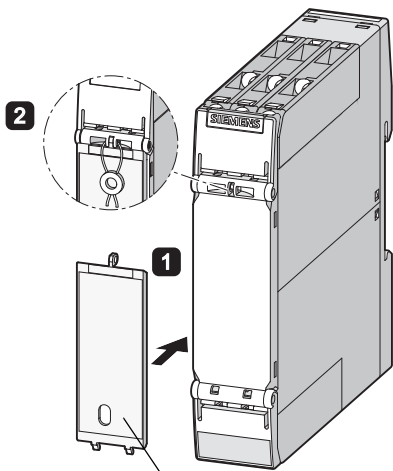
DE		GEFAHR Gefährliche Spannung. Lebensgefahr oder schwere Verletzungsgefahr. Vor Beginn der Arbeiten Anlage und Gerät spannungsfrei schalten. Die Installations- und Wartungsarbeiten an diesem Gerät dürfen nur von einer autorisierten Elektrofachkraft ausgeführt werden.
EN		DANGER Hazardous voltage. Will cause death or serious injury. Turn off and lock out all power supplying this device before working on this device. Installation and maintenance work on this device may only be carried out by an authorized electrician.
FR		DANGER Tension dangereuse. Danger de mort ou risque de blessures graves. Mettre hors tension avant d'intervenir sur l'appareil. Les travaux d'installation et d'entretien de cet appareil doivent uniquement être réalisés par une personne qualifiée en électricité.
ES		PELIGRO Tensión peligrosa. Puede causar la muerte o lesiones graves. Desconectar la alimentación eléctrica antes de trabajar en el equipo. Las tareas de instalación y mantenimiento de este equipo solo puede llevarlas a cabo un un electricista autorizado.
IT		PERICOLO Tensione pericolosa. Può provocare la morte o lesioni gravi. Scollegare l'alimentazione elettrica prima di eseguire interventi sull'apparecchiatura. L'installazione e la manutenzione di questo apparecchio devono essere effettuati solo da specialisti dell'elettronica autorizzati.
PT		PERIGO Tensão perigosa. Perigo de morte ou ferimentos graves. Desligue a alimentação eléctrica antes de iniciar os trabalhos no equipamento. Os trabalhos de instalação e manutenção neste equipamento somente podem ser realizados por electricistas autorizados.
BG		ОПАСНОСТ Опасно напрежение. Опасност за живота или опасност от тежки телесни повреди. Преди започване на работа изключете захранването на инсталацията или устройството. Монтажът и техническото обслужване на това устройство се извършват единствено от оторизиран електротехник.
CS		NEBEZPEČÍ Nebezpečné napětí. Nebezpečí smrtelného nebo těžkého úrazu. Před zahájením prací odpojte zařízení a modul od napětí. Instalační a údržbové práce smí na tomto přístroji provádět pouze kvalifikovaný elektrikář.
DA		FARE Farlig spænding. Livsfare eller fare for alvorlige kvæstelser. Inden arbejdet påbegyndes skal anlægget og enheden gøres spændingsfri. Installationer og vedligeholdelser på dette apparat må kun gennemføres af en autoriseret elektriker.
EL		ΚΙΝΔΥΝΟΣ Επικίνδυνη τάση. Κίνδυνος-θάνατος ή κίνδυνος σοβαρού τραυματισμού. Πριν από την έναρξη των εργασιών απομονώνετε την εγκατάσταση και τη συσκευή από την παροχή τάσης. Οι εργασίες εγκατάστασης και συντήρησης αυτής της συσκευής πρέπει να πραγματοποιούνται μόνο από εξουσιοδοτημένο ηλεκτρολόγο.
ET		OHT Ohtlik pinge. Eluohut või tõsiste vigastuste oht. Enne tööde algust tuleb süsteemi ja seadme pinge välja lülitada. Seadme paigaldus- ja hooldustööd võib teha ainult atesteeritud elektrik.
FI		VAARA Vaarallinen jännite. Vakava loukkaantumisaara tai hengenvaara. Laitte on kytkettävä jännitteettömiksi ennen töiden aloittamista. Tämän laitteen asennus- ja huoltotöitä saa suorittaa ainoastaan valtuutettu sähköteknikko.
HR		OPASNOST Opasni napon. Opasnost po život ili opasnost od teških ozljeda. Prije početka radova postrojenje i uređaj spoji bez napona. Radove instalacije i održavanja na uređaju smije izvoditi samo ovlašteno stručno elektrotehničko osoblje.
HU		VESZÉLY Veszélyes feszültség. Életveszély vagy súlyos sérülésveszély. A munkák megkezdése előtt végezze el a berendezés vagy készülék feszültség-mentesítését. Ezen az eszközön a telepítéssel és a karbantartással kapcsolatos feladatokat kizárólag megfelelő felhatalmazással rendelkező villamosági szakember végezheti.
LT		PAVOJUS Pavojinga įtampa. Pavojus gyvybei arba sunkaus susižalojimo pavojus. Prieš darbų pradžią atjunkite sistemos ir prietaiso įtampą. Šio įrenginio įrengimo ir techninės priežiūros darbus leidžiama atlikti tik įgaliotam elektrikui.
LV		BĪSTAMI Bīstams spriegums. Letālu seku vai smagu traumu risks. Pirms uzsākt darbu, atslēdziet iekārtu un ierīci no barošanas. Šīs ierīces uzstādīšanu un tehniskās apkopes darbus drīkst veikt vienīgi pilnvarots elektrikis.
NL		GEVAAR Gevaarlijke spanning. Levensgevaar of gevaar voor ernstig letsel. Schakel vóór aanvang van de werkzaamheden installatie en apparaat spanningsvrij. De installatie- en onderhoudswerken aan dit toestel mogen enkel door een geautoriseerde elektricien uitgevoerd worden.
PL		NIEBEZPIECZENSTWO Niebezpieczne napięcie. Zagrożenie życia lub niebezpieczeństwo ciężkich obrażeń. Przed rozpoczęciem wszelkich prac należy urządzenie i przyrząd odłączyć od sieci elektrycznej. Prace instalacyjne i konserwacyjne na tym urządzeniu może przeprowadzać wyłącznie posiadający odpowiednie kwalifikacje elektryk.
RO		PERICOL Tensiune periculoasă. Pericol de moarte sau de accidentări grave. Înainte de începerea lucrărilor, deconectați instalația și aparatul de la tensiune. Lucrările de instalare și întreținere pentru acest dispozitiv pot fi efectuate doar de către un electrician autorizat.
SK		NEBEZPEČENSTVO Nebezpečné napätie. Nebezpečenstvo ohrozenia života alebo vzniku ťažkých zranení. Pred začatím prác zariadenie a prístroj odpojte od napätia. Inštalácia a údržbové práce na tomto prístroji môže vykonávať výlučne autorizovaný elektrikár.
SL		NEVARNOST Nevarna napetost. Nevarnost za življenje ali nevarnost hudih poškodb. Pred začetkom dela je treba pri napravi in aparatu odklopiti napajanje. Inštalacijska in vzdrževalna dela na tej napravi sme izvesti samo pooblaščen električar.
SV		FARA Farlig spänning. Livsfara eller risk för allvarliga personskador. Koppla anläggningen och apparaten spänningsfri innan du påbörjar arbetena. Installation och underhåll av denna apparat får endast utföras av en behörig elektriker.
TR		TEHLİKE Tehlikeli gerilim. Ölüm tehlikesi veya ağır yaralanma tehlikesi. Çalışmalara başlamadan önce, sistemin ve cihazın gerilim beslemesini kapatınız. Bu cihazın montajı ve bakımı yalnız yetkili bir elektrik teknisyeni tarafından yapılmalıdır.
PY		ОПАСНОСТЬ Опасное напряжение. Опасность для жизни или возможность тяжелых травм. Перед началом работ отключить подачу питания к установке и к устройству. Работы по монтажу и техническому обслуживанию данного устройства должны производиться уполномоченным специалистом по электротехнике.
中文		危險 危險电压。將导致死亡或严重的人身伤害。 操作本设备前必须切断并锁定所有供电电源。该设备的安装和维护工作仅能由具备专业资格的电工完成。



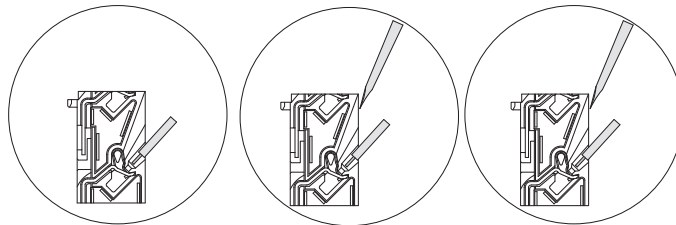
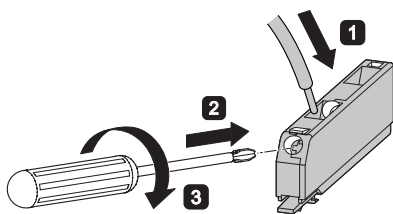
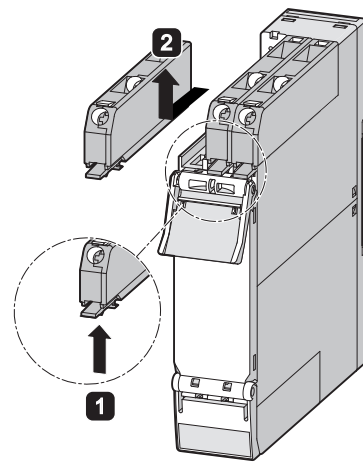
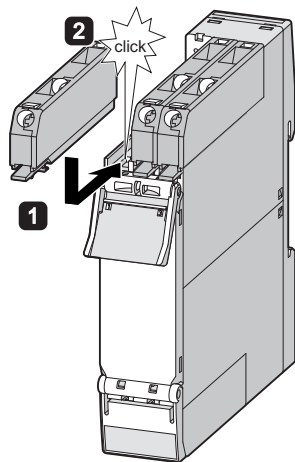





3ZY1321-1AA00 (17,5 mm)
3ZY1321-2AA00 (22,5 mm)

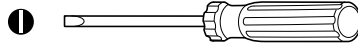

3ZY1122-1BA00	
	0,6 ... 0,8 Nm 5.2 to 7 lb/in
Ø 4.5 mm / PZ1	
	1 x 0,5 ... 4,0 mm ² 2 x 0,5 ... 2,5 mm ²
	1 x 0,5 ... 4,0 mm ² 2 x 0,5 ... 1,5 mm ²
	—
AWG	1 x 20 to 12 2 x 20 to 14

3ZY1122-2BA00	
	
DIN 5264 / 0,5 x 3 mm	3RA2908-1A
	1 x 0,5 ... 4,0 mm ²
	1 x 0,5 ... 2,5 mm ²
	1 x 0,5 ... 4,0 mm ²
AWG	1 x 20 to 12

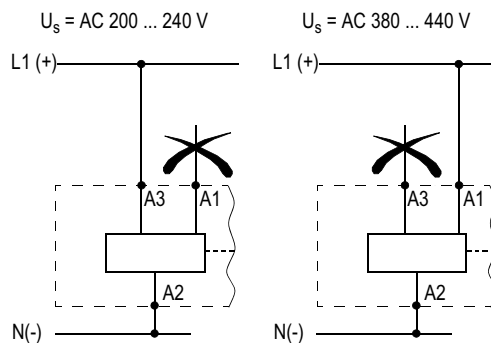
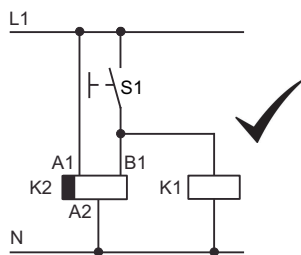

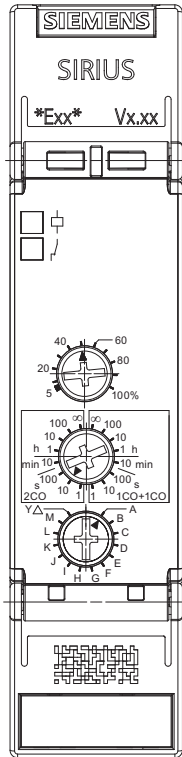

1	Power OFF	
2		A, B, C,... YΔ
		2CO 1CO+1CO
		t = 50s : t =
3	Power ON	

3RP2505- .A.30	16/15/18	1CO
3RP2505- .RW30	16/15/18; 26/25/28	2CO
3RP2505- .B. .0	16/15/18; 26/25/28	2CO
3RP2505- .B. .0	16/15/18; 22/21/24	1CO+1CO
3RP2505- .CW30	17/18	NO

A		B	
2CO	1CO+1CO	2CO	1CO+1CO

C		D	
2CO	1CO+1CO	2CO	1CO+1CO

E		F	
2CO	1CO+1CO	2CO	1CO+1CO

